

Owner's Manual with Installation Instructions

Banks Ram-Air[®] Intake System

2015-17 Ford F-150 5.0L Pickup Trucks

THIS MANUAL IS FOR USE WITH SYSTEM 41888

Gale Banks Engineering
546 Duggan Avenue • Azusa, CA 91702
(626) 969-9600 • Fax (626) 334-1743

Product Information & Sales: (888) 635-4565
Customer Support: (888) 839-5600
Installation Support: (888) 839-2700

bankspower.com

BANKS

Products available from Banks Power for the 2015-17 Ford F-150

Banks Ram-Air® Intake System

- Extensively tested & validated
- Increases air density, power & fuel economy
- Reduces exhaust gas temps (EGTs)
- Outflows stock up to 50%



Banks AutoMind® Programmer

- Clear and view OBDII Diagnostic Trouble Codes (DTC).
- Loaded with dyno-proven tuning files
- Speed Limiter adjustment capabilities.



Banks Straight-Shot® & Double-Shot® Water-Meth Injection

- Maximizes Engine Performance
- Cools Intake Temperatures
- Digital Controller (included)
- Greater flow than the competition
- Higher Pump Volume than others



Banks iDash® Digital Monitors

- 1.8", 4.3" or 5" touchscreen interface
- Interchangeable gauge display, read and clear codes, monitor engine diagnostics, log data, time your vehicle's runs and much more.



Monster® Exhaust System

- Cooler EGTs, more MPG & constant-duty power. Reduces boost pressure loss.



Note: Product availability, contents, features, and performance varies by year, make, and model. Please contact us for details.

For More Information please call (888)-635-4565
or Visit us online at www.bankspower.com

General Installation Practices

Dear Customer,

If you have any questions concerning the installation of your Banks Ram-Air System, please call our Technical Service Hotline at (888) 839-2700 between 7:00 am and 4:00 pm (PT). If you have any questions relating to shipping or billing, please contact our Customer Service Department at (888) 839-5600.

Thank you.

1. For ease of installation of your Banks Ram-air intake system, familiarize yourself with the procedure by reading the entire manual before starting work. This manual contains **16** pages of copy, illustrations and parts listing. If any pages are missing from this manual please call Gale Banks Engineering immediately for a replacement.

2. The exploded view of the Ram-Air assembly (pages **4-5**) provides only general guidance. Refer to each step and section diagram in this manual for proper instruction.

3. Throughout this manual, the left side of the vehicle refers to the driver's side, and the right-side to the passenger's side.

4. Disconnect the ground cable from the battery before beginning work. If there are two batteries, disconnect both.

5. Route and tie wires and hoses a minimum of 6 inches away from exhaust heat, moving parts and sharp edges. Clearance of 8 inches or more is recommended where possible.

6. During installation, keep the work area clean. If foreign debris is transferred to any Banks system component, clean it thoroughly before installing.

7. When raising the vehicle, support it on properly weight-rated safety stands, ramps or a commercial hoist. Follow the manufacturer's safety precautions. Take care to balance the vehicle to prevent it from slipping or falling. When using ramps, be sure the front wheels are centered squarely on the topsides; put the transmission in park; set the parking brake; and place blocks behind the rear wheels.

Tools Required:

- Flat and Phillips screwdriver
- 7mm and 8mm nut driver
- 13mm open or box-end wrench

Table of Contents

Section 1	4
General Assembly	
Section 2	6
OEM Intake System Removal	
Section 3	8
Banks Ram-Air® Assembly	
Section 4	16
Filter Maintenance	
Section 5	18
Decal Placement	

Section 1

GENERAL ASSEMBLY

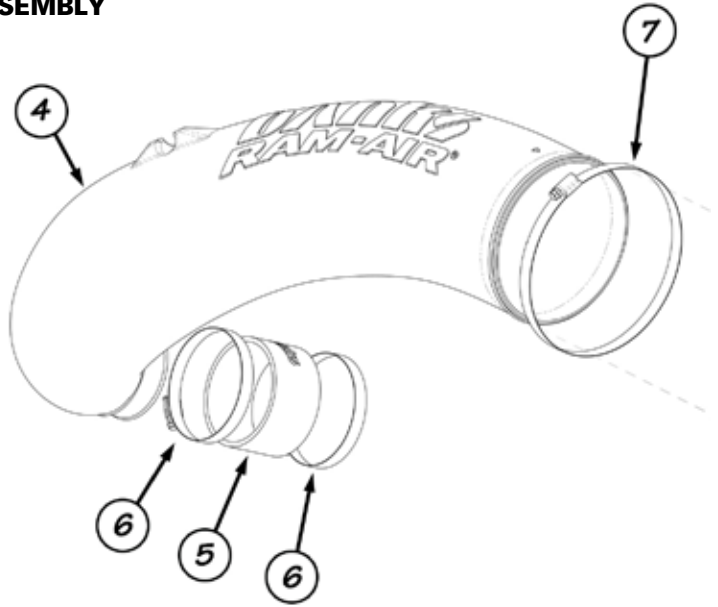

Item #	Description	Part #	QTY
1	Banks Ram-Air Housing	41886	1
2	Air Filter Element, Ram-Air System	41885	1
3	Window, Banks Logo - Air Filter Housing	41788	1
4	Intake Tube, Ram-Air System	41889	1
5	Hose, 3.5" ID X 2.0" Long	94211	1
6	Hose clamp, #56 w/ liner (3.5")	92857	2
7	Hose Clamp, #104 - Air Filter Mount	92904	1
8	Retainer, Push-Type, Black-11/16" Head x 1/4", Nylon 6	92020	2
9	Machine Screw Truss HD Phil 1/4"-20 x 3/8" S/S	91125	4
10	Banks Urocal	96009	1
11	Decal, Stop Do Not Discard	96002	1
12	Product Registration Card	96399	1
13	CARB E.O. decal	96025	1

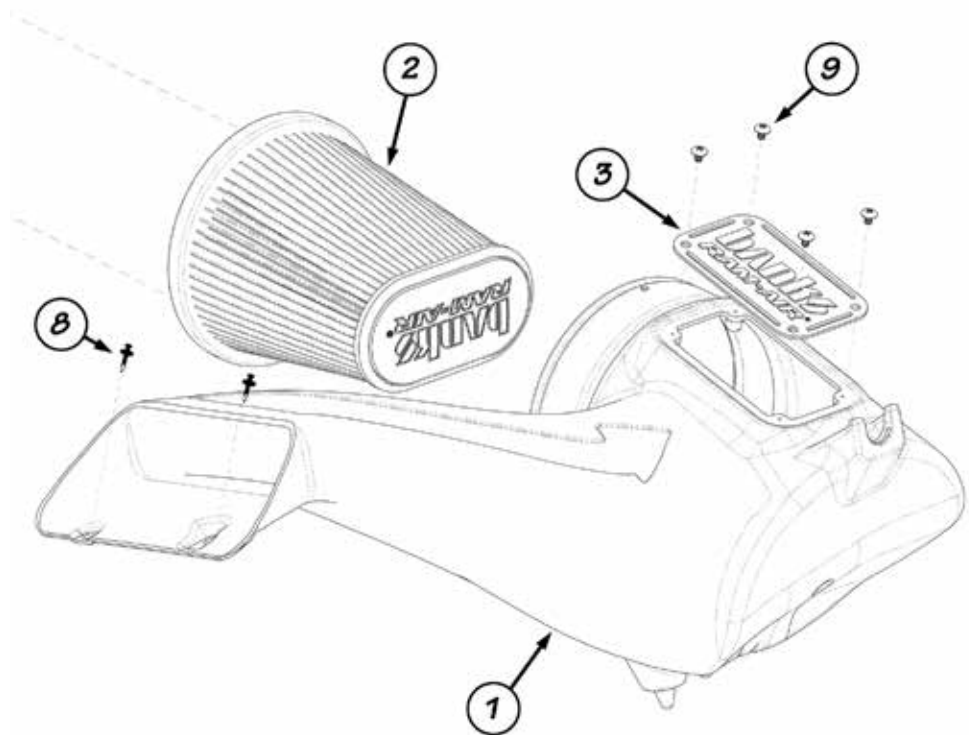

**bankz
POWER**

10



11



12



13

Section 2

OEM INTAKE SYSTEM REMOVAL

- 1.** Unbolt the OEM airbox from the vehicle. See **Figure A (1)**.
- 2.** Loosen the band clamp on OEM intake tube at connection to OEM airbox. See **Figure A (2)**.
- 3.** Remove the two plastic push type retainer clips at the air duct entrance. See **Figure A (3)**.
- 4.** Remove the OEM airbox.
- 5.** Remove EVAP (lighter color connector in **Figure B**) and PCV (black connector in **Figure C**) lines from the intake tube. Push the black clip on the EVAP connector then pull to remove. Gently pull back the grey lever on the PCV connector then pull to remove.

Figure A

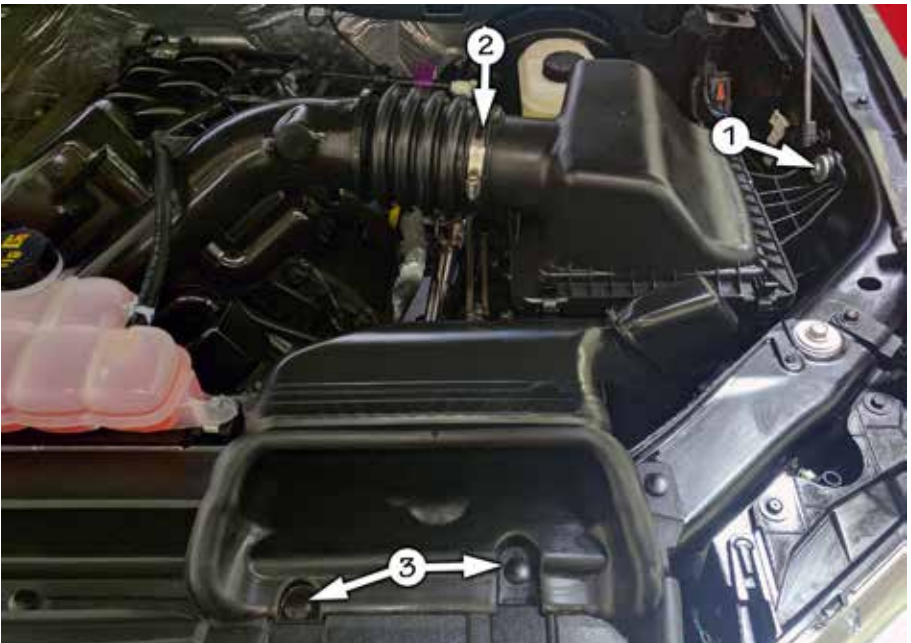
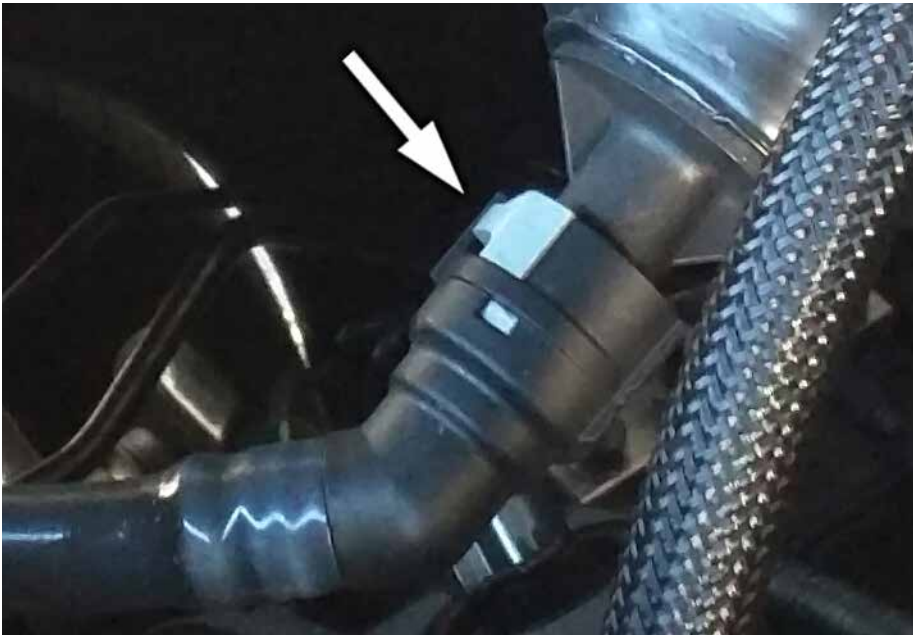

Figure B



Figure C



Section 3

BANKS RAM-AIR® ASSEMBLY

6. Loosen the band clamp on OEM intake tube at connection to throttle body (1), and unhook the coolant hose from the intake tube (2). See **Figure D**.

7. Remove the intake tube.

8. Remove the two M6 bolts from the coolant expansion tank to provide extra room during the intake tube install. See **Figure E**.

9. Connect the filter to the intake tube, and align the key on the intake tube to the keyway at the air filter base. Secure the filter to the intake tube using the supplied hose clamp. See **Figure F**.

Figure D



Figure E



Figure F

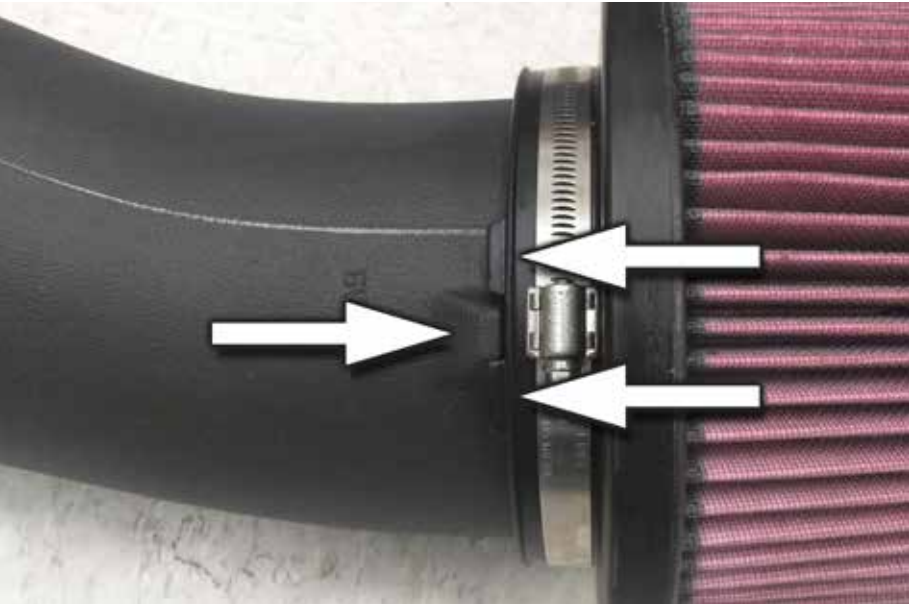

Section 3

BANKS RAM-AIR® ASSEMBLY (continued)

- 10.** Attach the hose couplers to the intake tube, and use the supplied hose clamp to secure the coupler to the intake tube.
- 11.** Install the Banks Clear Window onto the housing and tighten the 4 pan head Phillips fasteners to secure it. Do not over tighten. See **Figure G**.
- 12.** Insert the air filter at a slight angle and push the filter completely into the housing. See **Figure H**.
- 13.** Note the alignment arrow at the filter base and on the housing for correct orientation. See **Figure I**.

Figure G



Figure H

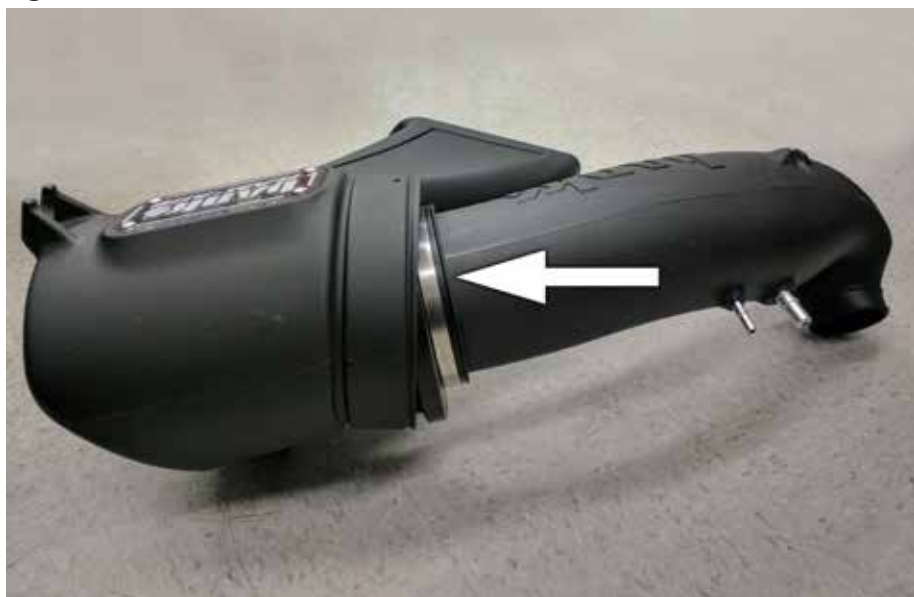

Figure I



Section 3

BANKS RAM-AIR® ASSEMBLY (continued)

14. Install the intake assembly and connect the hose coupler to the throttle body. Secure the hose coupler with the supplied hose clamps. See **Figure J**.

15. Secure the housing duct using the 2 supplied plastic push-type retainers. See **Figure K**.

16. Remove the steel sleeve and then the rubber bushing from the OEM airbox lid. See **Figure L**.

Figure J



Figure K



Figure L

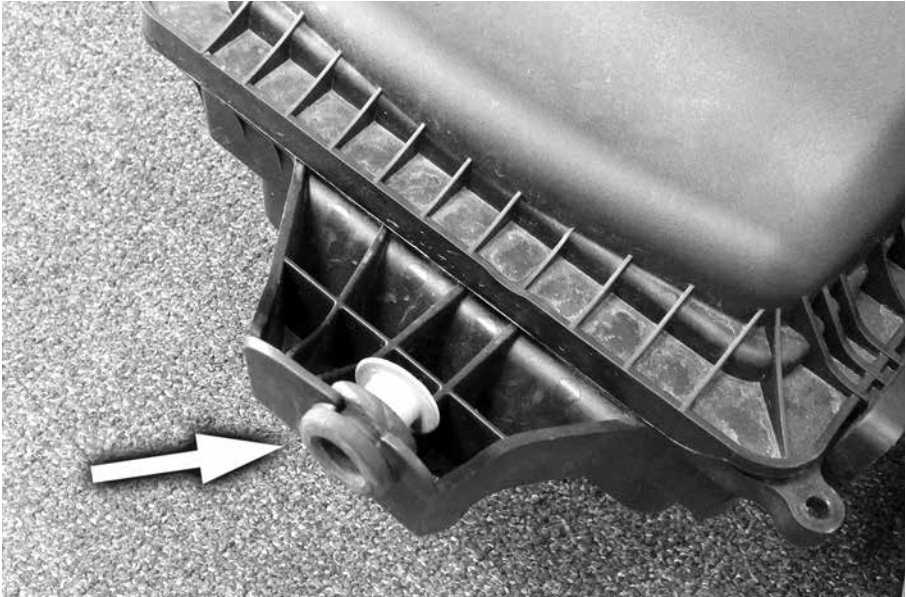

Section 3

BANKS RAM-AIR® ASSEMBLY (continued)

17. Bolt the rubber bushing and the steel sleeve with the original hardware. See **Figure M**.

18. Reinstall the two M6 bolts from the coolant expansion tank.

19. Reinstall the EVAP and PCV lines to the intake tube. Position the coolant line to its mounting provision on the intake tube. See **Figure N**.

20. Your system contains a CARB EO label for emissions purposes. This label should be placed on the grill/radiator cross member inside the engine compartment, so that it is easily seen by an emissions technician.

21. This completes the installation of the Banks Ram-Air Intake system. Check all hose clamps for tightness and connectors for a sure fit and intake tube is not touching any engine components.

Figure M



Figure N



Section 4

AIR FILTER CLEANING INSTRUCTIONS

OILED AIR FILTER ONLY

NOTICE: The Banks Ram-Air Oiled Air Filter comes pre-oiled and no oiling is necessary for initial installation. Use Banks Ram-Air Filter Cleaning System (part#90094), available from Gale Banks Engineering to service the Air Filter. Follow the instructions included with the cleaning system to clean and re-oil your Bank Ram-Air Oiled Air Filter.

1. PRE-CLEANING

Tap the element to dislodge any large embedded dirt, then gently brush with a soft bristle brush. **NOTE: If complete cleaning is not practical at this time, reoil the element and reinstall in your vehicle.**

2. SPRAY-ON CLEANING

Spray air-filter cleaner liberally onto the entire element and let soak for 10 minutes.

3. PAN CLEANING

Large air-filter elements can be rolled or soaked in a shallow pan of air-filter cleaner. Remove immediately and let soak for approximately 10 minutes.

NOTICE: NEVER use gasoline, steam, caustic solutions, strong detergents, high-pressure nozzles, or cleaning solvents to clean the filter element. All of these can cause harm to the filter media as well as SHRINK and HARDEN the rubber end caps.

4. RINSING

Rinse off the element with low-pressure water. Tap water is okay. Always flush from the clean side to dirty side. This removes the dirt

and does not drive it into the filter.

5. DRYING

Always dry naturally. After rinsing, shake off all excess water and let the element dry naturally.

6. AEROSOL OILING

After cleaning air filter always reoil before using. Spray air filter oil down into each pleat with one pass per pleat. Wait 10 minutes and re-oil any white spots still showing.

7. OILING HINTS

Never use a Banks Ram-Air filter without oil (the filter will not stop the dirt without the oil). Use only air filter oil. Air-filter oil is a compound of mineral and animal oil blended with special polymers to form a very efficient tack barrier. Red dye is added to show just where you have applied the oil. Eventually the red color will fade but the oil will remain and filter the air. NEVER USE Automatic Transmission Fluid. NEVER USE Motor Oil. NEVER USE Diesel Fuel. NEVER USE WD40, LPS, or other light-weight oils.

8. REINSTALL

Reinstall your Banks Ram-Air filter element with proper care. Make sure the element seats properly in the filter case. Install the cover making sure it's in the right position. Tighten all the nuts, bolts, screws or clips to factory specifications.

9. DO NOT DISCARD

Affix the "Do Not Discard" sticker to the filter case (included with every Banks replacement element). Make sure you put the sticker in a highly visible place to alert your mechanic not to discard.

10. PERFORMANCE HINTS

Service every 50-100,000 miles on

street-driven applications. Service more often in offroad or heavy-dust conditions. If an air-filter restriction gauge is installed, then change the element when the air-filter restriction reaches 18"–H.O.

⚠ CAUTION: **Extremely fine dust from agriculture or offroad use will pull the oil from the element. Frequent reoiling of the element's clean side might be required. Completely service when practicable. For extra protection use an air-filter sealing grease on rubber ends of the element. Service only with air-filter cleaner and air-filter oil.**

DRY FILTER CLEANING

Clean every 50-100,000 miles on street-driven applications. Clean more often in offroad or heavy-dust conditions. If an air-filter restriction gauge is installed, then change the element when the air-filter restriction reaches 18"–H.O.

1. PRE-CLEANING

Carefully tap the air filter element to dislodge any large embedded dirt or debris.

2. CLEANING

Spray an appropriate DRY AIR-FILTER CLEANER SOLUTION liberally onto both sides of the entire filter element with the majority applied to the dirty side. Soak for 10 minutes. Do not allow the DRY AIR-FILTER CLEANER SOLUTION to dry on the air filter.

NOTICE: **NEVER use gasoline, steam, caustic solutions, strong detergents, high-pressure nozzles, or cleaning solvents to clean the filter element.** All of these can cause harm to the filter media as well as SHRINK and HARDEN the rubber end caps.

3. RINSING

Rinse the filter element with cool or warm (not hot) water from the clean side out in order to flush the dirt out of the filter. It may be necessary to use your fingers on the hose to apply light water pressure. Repeat steps 2 and 3, until the water flowing through the media is completely clear of any dirt and debris.

4. DRYING

After rinsing, gently shake off excessive water and allow to dry naturally. Re-install the filter onto the intake system, airbox or custom assembly once it is dry or just slightly damp. Follow all original installation instructions.

5. REINSTALL

Reinstall your Banks Ram-Air filter element with proper care. Make sure the element seats properly in the filter case. Install the cover making sure it's in the right position. Tighten all the nuts, bolts, screws or clips to factory specifications.

6. DO NOT DISCARD

Affix the "Do Not Discard" sticker to the filter case (included with every Banks replacement element). Make sure you put the sticker in a highly visible place to alert your mechanic not to discard.

7. PERFORMANCE HINTS

Service every 50-100,000 miles on street-driven applications. Service more often in offroad or heavy-dust conditions. If an air-filter restriction gauge is installed, then change the element when the air-filter restriction reaches 18"–H.O.

-END, SECTION 4-

Section 5

PROPER DECAL PLACEMENT

Your system includes two Banks Power decals that have been designed to compliment the Ford badging on your truck. We have provided measurements, which will allow you to place these decals in a position that gives a clean OEM look. See figure below.

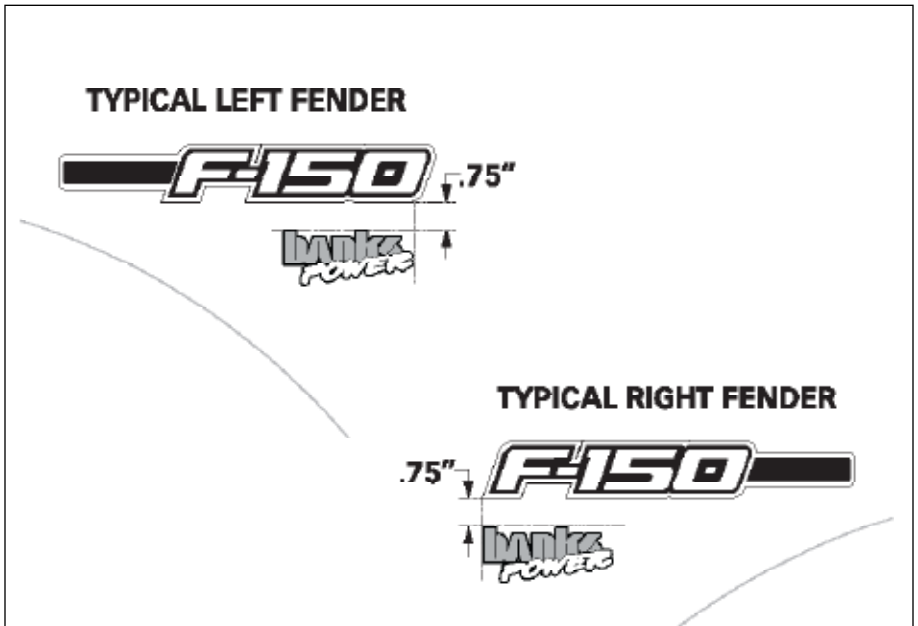

Gale Banks Engineering
546 Duggan Avenue • Azusa, CA 91702
(626) 969-9600 • Fax (626) 334-1743

Product Information & Sales: (888) 635-4565
Customer Support: (888) 839-5600
Installation Support: (888) 839-2700

bankspower.com